

Have a question or need assistance?

Ooma has a wealth of available resources if you need assistance.

Support articles. Access our comprehensive knowledge base at <https://help.ooma.com/en/>

Speak with a support specialist 24/7 at **1-833-603-4247**

Ooma[®]

525 Almanor Avenue, Suite 200
Sunnyvale, CA 94085

Learn more at www.ooma.com
or call 1-833-603-4247

This device is intended for commercial use only, do not use this device inside a residence

This equipment has been tested and found to comply with the limits for a Class A digital device, pursuant to part 15 of the FCC Rules. These limits are designed to provide reasonable protection against harmful interference when the equipment is operated in a commercial environment. This equipment generates, uses, and can radiate radio frequency energy and, if not installed and used in accordance with the instruction manual, may cause harmful interference to radio communications. Operation of this equipment in a residential area is likely to cause harmful interference in which case the user will be required to correct the interference at his own expense.

© 2021 Ooma, Inc. All rights reserved. Patent Pending. Ooma, Ooma Telo, Ooma Connect 4G Adapter, Ooma Premier, Ooma HD3 Handset, Ooma Linx, Ooma Home Security, and the Ooma logo are trademarks or service marks of Ooma, Inc. Other company and product names mentioned herein are trademarks of their respective companies. Mention of third-party products is for informational purposes only and constitutes neither an endorsement nor a recommendation. Ooma assumes no responsibility with regard to the performance or use of these products. P/N: 700-0303-100

Ooma[®] AirDial

Quick Start Guide



Contents

Package Contents	4
Account Activation	5
Assembly	6
Connect AirDial to the Internet.....	7
Installation or Mounting Instructions.....	9
Monitoring and Configuration.....	10
Quick Reference Guide.....	11
Optional Accessories	12
Battery Replacement.....	13
Device Specifications.....	14
Support	15
Appendix I.....	16
Appendix II	17

Pre-Install Steps

Please complete the following steps prior to starting the installation:

1. Confirm your existing devices and services are working as intended.
2. Place all alarm panels in test mode before making any changes.
3. If you need to complete number porting call into Ooma Enterprise support once you have your AirDial equipment online and tested.

Package Contents

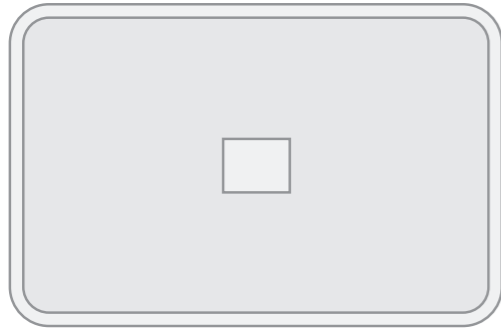

Ooma AirDial

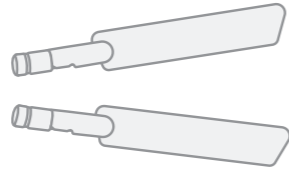

Two External Detachable LTE Antennas

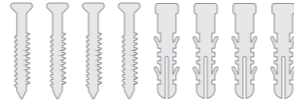

Mounting Screws and Anchors



4x Phone Wires

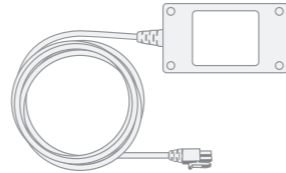

Power Adapter



Mounting Bracket

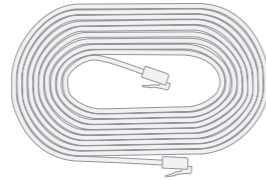

Ethernet Cable (CAT5)

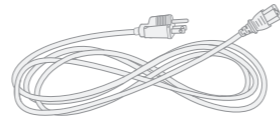

Power Adapter Cable

Account Activation

If the packaging of your AirDial says it is already activated, then you may skip the activation step. You should have received an email containing your account number, the device's serial number, and the phone number of your pre-activated AirDial when the device shipped.

Otherwise, you will need to add your AirDial to your Ooma account by visiting <http://rdm.ooma.com/>.

- If you are a new Ooma customer, choose **Create Account**.
- If you already have an Ooma account, choose **Add Device**.

The activation code can be found on the FCC label on the bottom of the device.

Once you have activated the device, you may continue to the next step.



FCC label is attached to the bottom of the AirDial



Assembly

1. Connect the two included LTE antennas to the back of the AirDial device **A**. Screw the swivel nuts clockwise until they are finger tight and are holding the antenna in a steady upright position. Do not over-tighten.

NOTE: The swivel nut on the antenna cannot be separated from the rest of the antenna assembly.

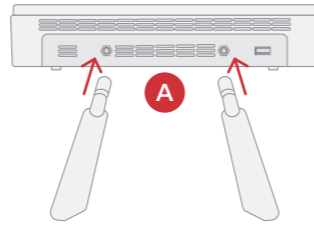

2. Attach the included AC power adapter to the AirDial unit **B** and plug the other end into a wall. The power adapter has a snapping connector to prevent accidental disconnects. To remove it from the AirDial unit, squeeze the connector from the top and bottom and gently pull it out.

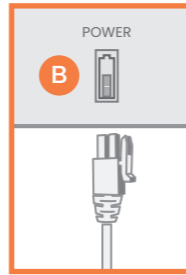

3. Turn the power switch to the ON position **C**.

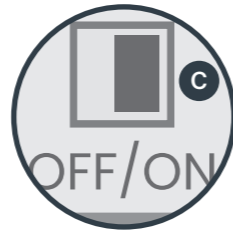

Connect AirDial to the Internet

When your AirDial starts up for the first time, it will download and install updates. This process can take up to five minutes, during which time the LCD panel might go blank. When the AirDial is powered on and ready for use, its status will change to **IN-SERVICE**.

You can connect the four ports labeled 1-4 on the back of the AirDial to up to four devices that require POTS replacement (e.g., dialers, alarms, entry systems, communicators).

The LCD on the front of the AirDial **A** shows the status of each phone line, the LTE signal strength, the battery's charge, Status of the AC adapter's status, and the overall system status.



Placement Guidelines

Your AirDial must be installed in an area with suitable LTE cellular coverage.

To test the level of coverage, you can check the signal strength indicator bars on the AirDial unit's LCD display. If the indicator shows two bars or fewer, try moving the AirDial to a different location.

The AirDial includes a built-in battery that powers the unit if the power is disconnected. You can use the battery to move your AirDial between locations to identify a spot with ideal signal strength.

The AirDial comes with four phone cables that can be used to connect it to an alarm, dialer, patch panel, or other telephony equipment. If the AirDial is installed in a location that is more than six feet from the equipment for which it will provide POTS replacement service, then you will need a longer phone cable to connect it to your equipment. You can purchase longer phone cables from a local hardware store, or you can order a 50 ft phone wire from ooma.com.

LTE PLACEMENT ADVISORY

The AirDial and the included antennas should only be installed indoors or in an enclosed environment away from moisture and high heat. **For the best LTE signal, here are some dos and don'ts:**

- **Do** place the adapter in an area with good cellular reception like a room with a window
- **Do** install the adapter on the highest possible floor of your building
- **Do** double check the device's LTE signal prior to installation
- **Don't** install the adapter in a basement
- **Don't** install the adapter near large concrete, sheet metal, or steel slabs
- **Don't** install the adapter near an electrical cabling cabinet or large volumes of wire mesh
- **Don't** install the adapter near any plumbing

Installation or Mounting Instructions

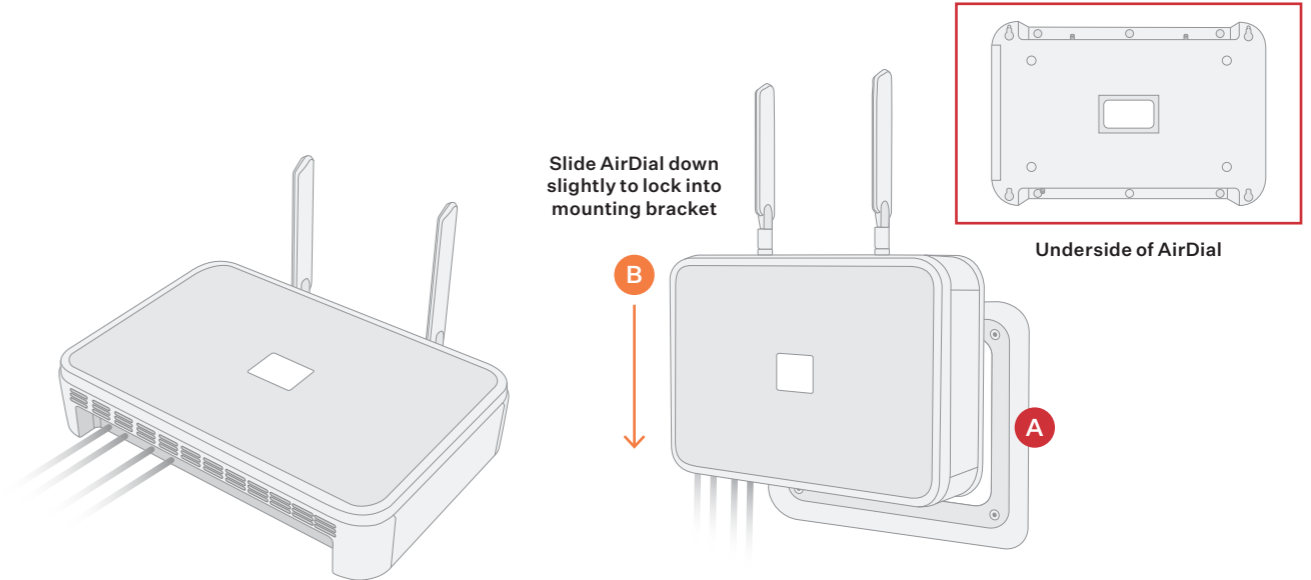

The AirDial device can sit flat on a horizontal surface like a desk or shelf, or it can be mounted vertically on a wall.

To mount the device on a wall, attach the included mounting bracket **A** to the wall. If necessary, use the included plastic wall anchors. Align the AirDial with the mounting bracket and then slide it down slightly to lock it into place **B**. The cables should hang beneath the device.

Monitoring and Configuration

The AirDial can be monitored and configured remotely from any web browser. To configure a device, visit <http://rdm.ooma.com>

Log in with your Ooma username and password. You will see a list of devices associated with your account.

For additional information about existing devices, adding new devices, device settings and notification options visit <http://rdm.ooma.com>

Quick Reference Guide

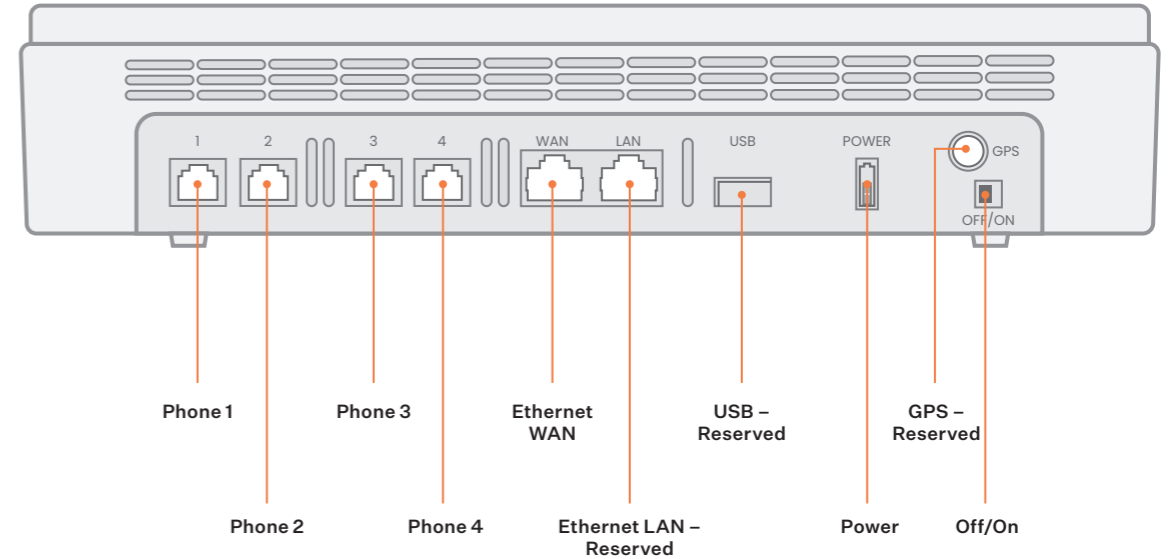

- **Phone 1-4:** Connect to your telephony device using an RJ11 wire
- **Ethernet WAN:** Use an Ethernet cable to connect to a router or switch's LAN port, or to connect directly to a modem
- **Power:** Use the provided AC adapter to connect to a power outlet
- **Off/On:** Toggle the power on and on

Optional Accessories

Replacement battery

If your battery becomes depleted, you can purchase and install a replacement. Visit ooma.com or contact a customer support representative to learn more and buy now.



Extended phone cable

If the included phone cable isn't long enough to reach your telephony device at the installation site, you can purchase a longer cable. Visit ooma.com to order a 50-foot cable direct from Ooma, or head to your local hardware store to view their selection of phone cables.

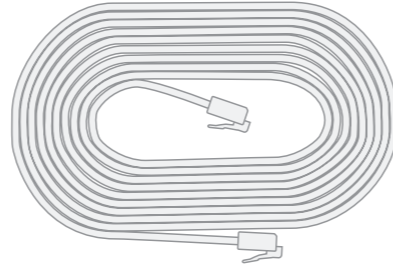

Coax extension cables for antennas

You can extend the range of your antennas by connecting them to **SMA coax extension cables**. If you'd like to do this, visit your local hardware store or your favorite online retailer to explore their selection.

The quality of your signal depends on the cable's length and impedance. Ooma recommends that coax extension cables be no longer than 10 feet and have low impedance.

Be sure to purchase a cable with a male connector on one end and a female connector on the other.

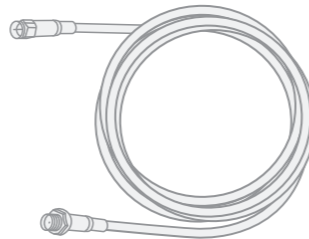

Battery Replacement

Should your batter become depleted, you can purchase and install a new one.

To replace the old battery pack:

1. Open the door on the right side of the device.
2. Remove the screw that holds the battery cover in place.
3. Disconnect the battery from the white electrical connector:
 - Depress the top locking tab.
 - Hold the wires firmly to secure them as you disconnect the connector.
 - If disconnecting the battery is difficult, carefully move the wires back and forth within 15 degrees of the connection point.
4. Remove the old battery.
5. Insert the new battery.
6. Connect the battery cable to the in the white electrical connector by inserting the socket straight into the header with the locking tab up until it clicks.
7. Reinsert the battery cover, secure it with the screw removed in Step 2, and close the access door.

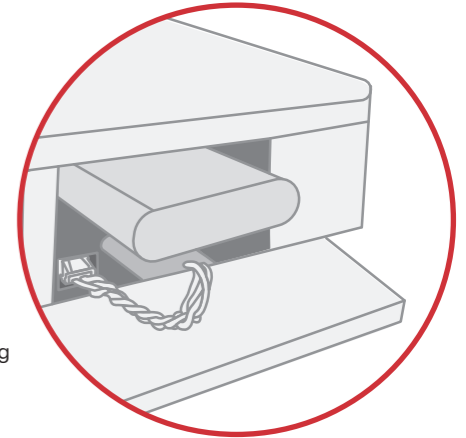

BATTERY WARNING: The battery used in this device may present a risk of fire or chemical burn if mistreated. Do not disassemble, heat, or incinerate. Replace battery with Ooma authorized replacement pack only. Use of another battery may present a risk of fire or explosion.

Dispose of battery properly. Keep away from children. Do not disassemble and do not dispose of in fire.

Device Specifications

Processor	<ul style="list-style-type: none">Dual-core ARM Cortex A9 CPU
Modem	<ul style="list-style-type: none">Quectel EG95-NAXD Cat-4 LTE
LTE Band Support	<ul style="list-style-type: none">B2/B4/B5/B12/B13/B25/B26
LTE Data Rates	<ul style="list-style-type: none">Up to 150 Mbps down and 50 Mbps up
Antennas	<ul style="list-style-type: none">Two Wideband 5G/4G Terminal Mount AntennasHinged 90° termination with SMA(M) Connector
SIM Cards	<ul style="list-style-type: none">Dual micro-SIM support
Ethernet	<ul style="list-style-type: none">One RJ-45 10/100/1000 Ethernet WAN portOne RJ-45 10/100/1000 Ethernet LAN port
FXS Ports	<ul style="list-style-type: none">Four RJ-11 analog FXS ports
Telephony	<ul style="list-style-type: none">55Vrms Low Power Ringing
Power Adapter	<ul style="list-style-type: none">AC-DC Adapter w/ MicroFit+ connector
Power Input	<ul style="list-style-type: none">100-240 VAC 50-60Hz
Power Output	<ul style="list-style-type: none">12VDC/3A 36W
Battery Backup	<ul style="list-style-type: none">Replaceable battery pack 3S3P Li-ion battery: 10.95V, 3ACapacity 85.4 Wh (7.8 Ah) provides > 8 hours of standby time
Display	<ul style="list-style-type: none">320x240 LCD display
Switches	<ul style="list-style-type: none">Master On/OffFactory reset (recessed)
Dimensions	<ul style="list-style-type: none">W 30cm x H 6cm x D 20cm when sitting horizontally
Operating Temperature	<ul style="list-style-type: none">0 – 40° C
Warranty	<ul style="list-style-type: none">1-Year Limited Warranty

Support

Need help? Ooma has a wealth of available resources to help if you need assistance.

Support Articles and User Manuals. Access our comprehensive knowledge base at <https://help.ooma.com/en/>

Live Customer Care. Speak with a support specialist 24/7 at 1-833-603-4247 (US)

Appendix I

Connecting AirDial to an emergency phone or monitoring system dialer

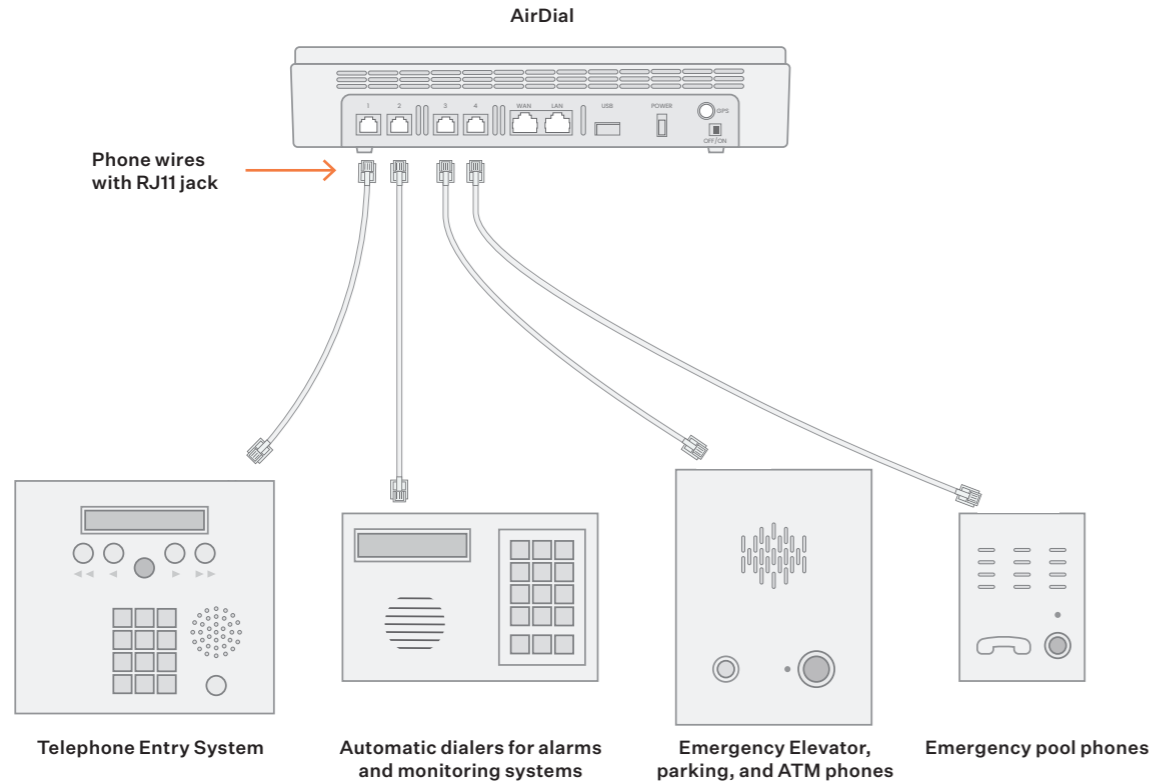

Appendix II

Connecting AirDial to Digital Alarm Communication Transmitter (DACT)

